

Telecommunications

- Tele (Far) + Communications
- Early telecommunications
 - smoke signals and drums
 - visual telegraphy (or semaphore in 1792)
- Telegraph and telephone
 - Telegraph (1839)
 - Telephone (1876)
- Radio and television
- Telephony
 - Voice and Data

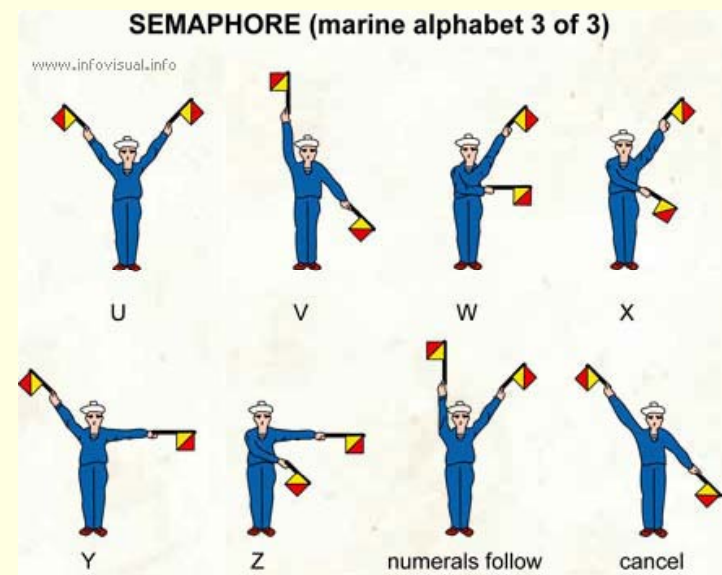

Communications and Networks

- Data Communications

- Transmission of signals

- Encoding, interfacing, signal integrity, multiplexing etc.

- Networking

- Topology & architecture used to interconnect devices

- Networks of communication systems

Network Trends (1980-Present)

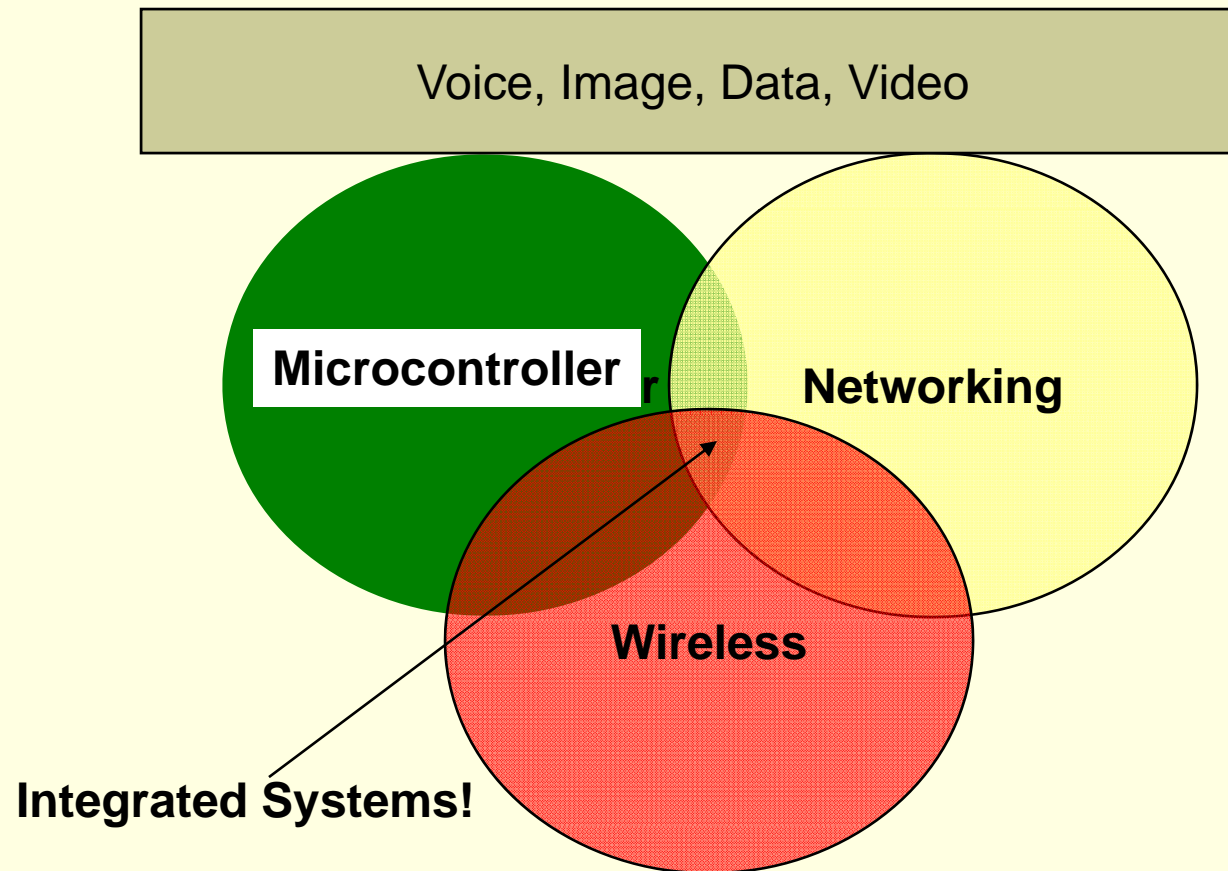

Communication Systems

- **Process** describing **transfer** of information, data, instructions between one or more systems through some media
 - Examples
 - people, computers, cell phones, etc.
 - Computer communication systems
- Signals passing through the communication channel can be **Digital**, or **analog**
 - Analog signals: continuous electrical waves
 - Digital signals: individual electrical pulses (bits)
- Receivers and transmitters: desktop computers, mainframe computers, etc.

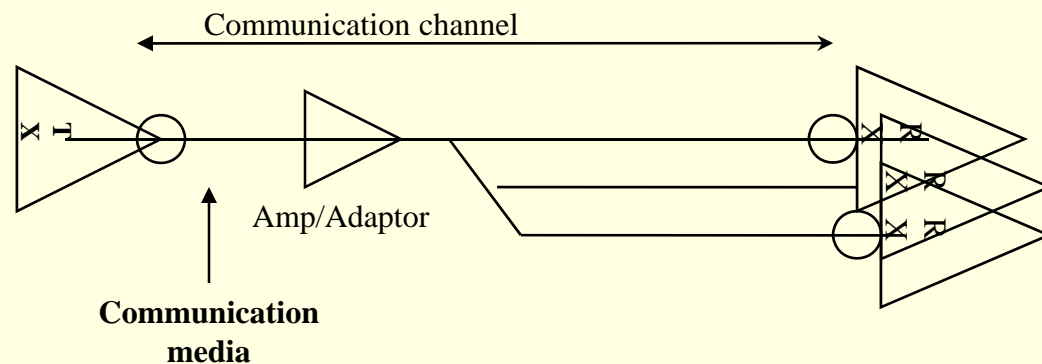

Communication Systems

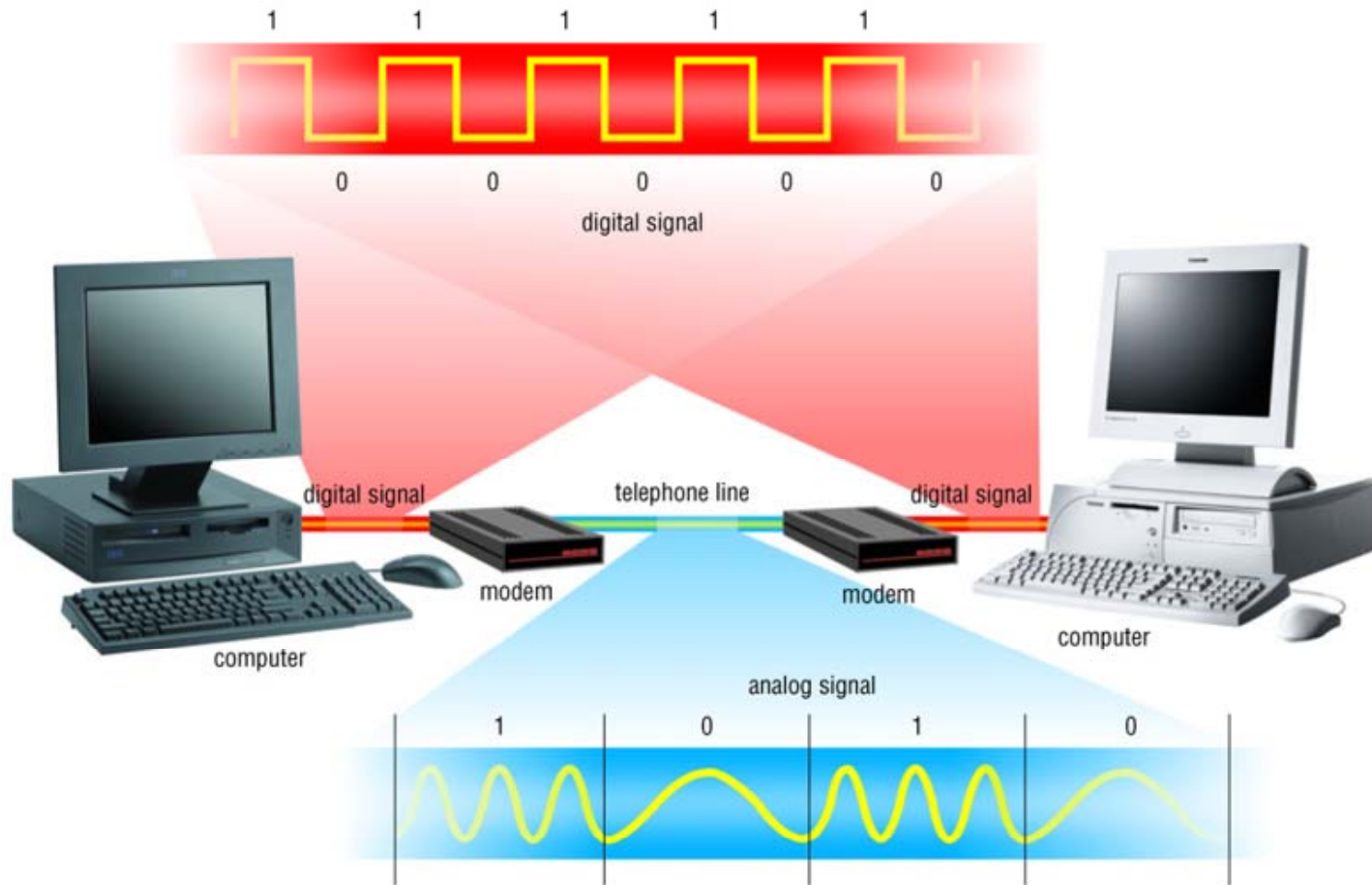

Communications Components

- Basic components of a communication system
 - Communication technologies
 - Communication devices
 - Communication channels
 - Communication software



A Communications Model

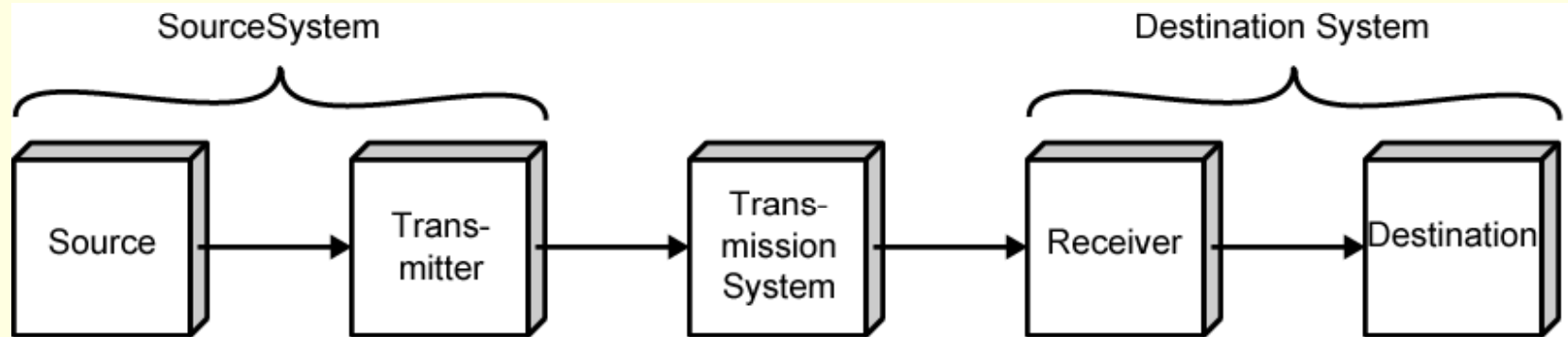

(a) General block diagram



(b) Example

Communications Tasks

Transmission system utilization	Addressing
Interfacing	Routing
Signal generation	Recovery
Synchronization	Message formatting
Exchange management	Security
Error detection and correction	Network management
Flow control	

Data Communications Model

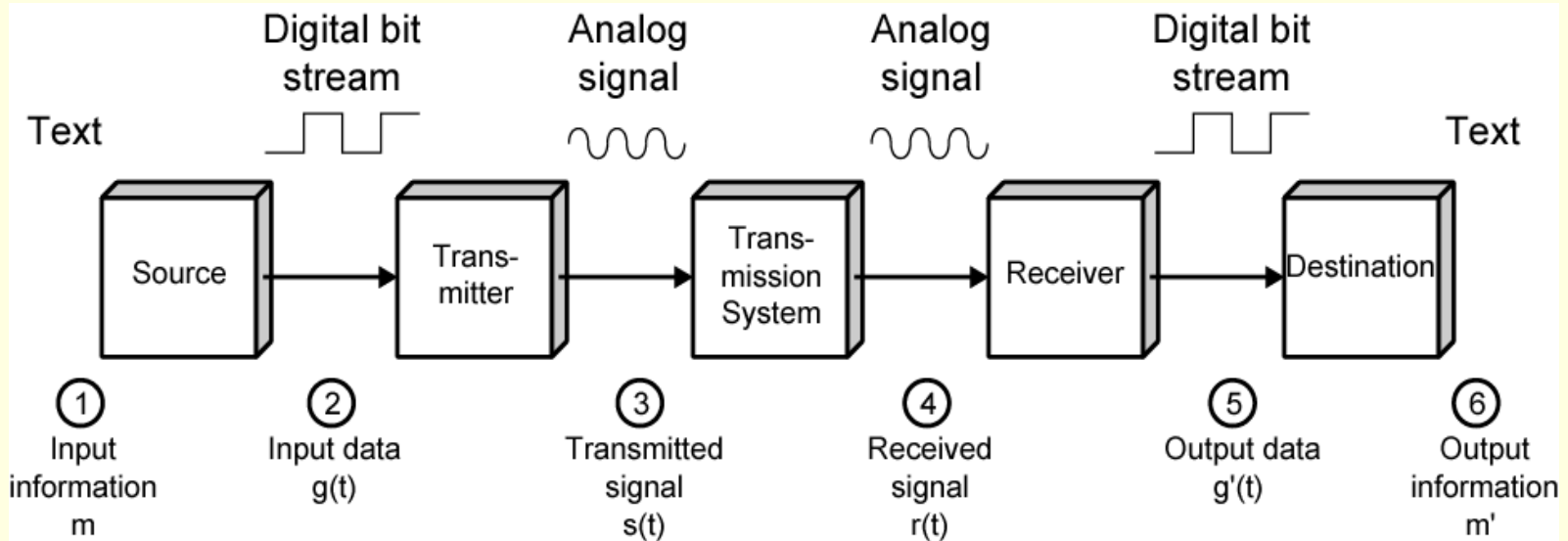

Communication Technology Applications

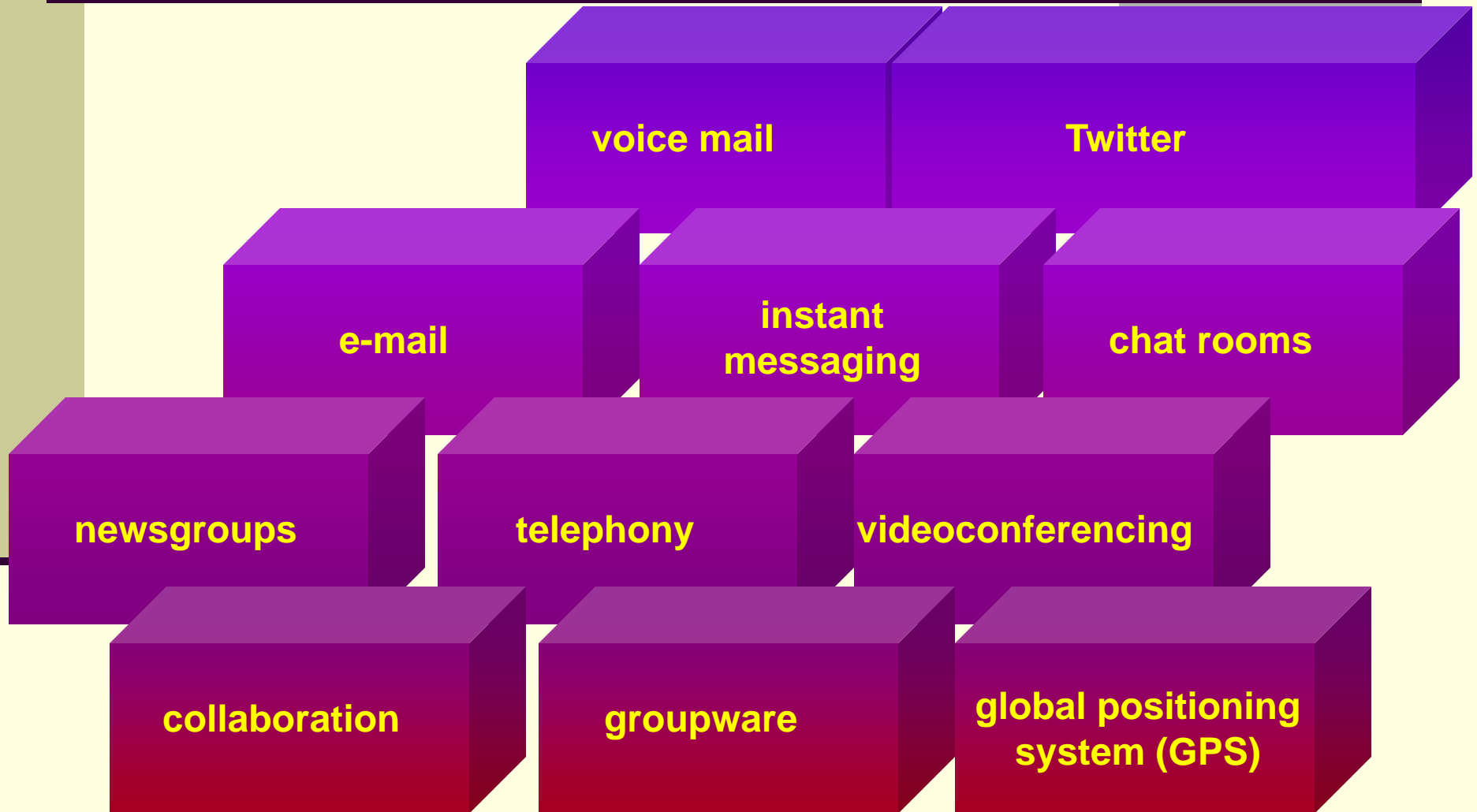

Communication Technologies - Applications

- Different technologies allowing us to communicate
 - **Examples:** Voice mail, fax, email, instant message, chat rooms, news groups, telephony, GPS, and more
- Voice mail: Similar to answering machine but digitized
- Fax: Sending hardcopy of text or photographs between computers using fax modem
- Email: electronic mail – sending text, files, images between different computer networks - must have email software
 - More than 1.3 billion people send 244 billion messages monthly!
- Chat rooms: Allows communications in real time when connected to the Internet
- Telephony: Talking to other people over the Internet (also called VoIP)
 - Sends digitized audio signals over the Internet
 - Requires Internet telephone software
- Groupware: Software application allowing a group of people to communicate with each other (exchange data)
 - Address book, appointment book, schedules, etc.
- GPS: consists of receivers connected to satellite systems
 - Determining the geographical location of the receiver
 - Used for cars, advertising, hiking, tracking, etc.

Communication Devices

- Any type of **hardware** capable of transmitting data, instructions, and information between devices
 - Functioning as receiver, transmitter, adaptor, converter
 - Basic characteristics: How **fast**, how **far**, how **much data**!
- Examples: Dial-up modems, ISDN, DSL modems, network interface cards
 - **Dial-up modem**: uses standard phone lines
 - Converts digital information into analog
 - Consists of a modulator and a demodulator
 - Can be external, internal, wireless
 - **ISDN and DSL Modem**: Allows digital communication between networks and computers
 - Requires a digital modem
 - Digital is better than analog – why?
 - **Cable modem**: a modem that transmits and receives data over the cable television (CATV) network
 - Also called **broadband modem** (carrying multiple signals)
 - The incoming signal is split
 - Requires a cable modem
 - **Network interface cards**: Adaptor cards residing in the computer to transmit and receiver data over the network (NIC)
 - Operate with different network technologies (e.g., Ethernet)

Communication Software

- Examples of applications (Layer 7) take advantage of the transport (Layer 4) services of TCP and UDP
 - **Hypertext Transfer Protocol (HTTP):** A client/server application that uses TCP for transport to retrieve HTML pages.
 - **Domain Name Service (DNS):** A name-to-address translation application that uses both TCP and UDP transport.
 - **Telnet:** A virtual terminal application that uses TCP for transport.
 - **File Transport Protocol (FTP):** A file transfer application that uses TCP for transport.
 - **Trivial File Transfer Protocol (TFTP):** A file transfer application that uses UDP for transport.
 - **Network Time Protocol (NTP):** An application that synchronizes time with a time source and uses UDP for transport.
 - **Border Gateway Protocol (BGP):** An exterior gateway routing protocol that uses TCP for transport. BGP is used to exchange routing information for the Internet and is the protocol used between service providers.

Communication Channels

- A **channel** is a path between two communication devices
- **Channel capacity**: How much data can be passed through the channel (bit/sec)
 - Also called **channel bandwidth**
 - The smaller the pipe the slower data transfer!
- Consists of one or more **transmission media**
 - Materials carrying the signal
 - Two types:
 - Physical: wire cable
 - Wireless: Air

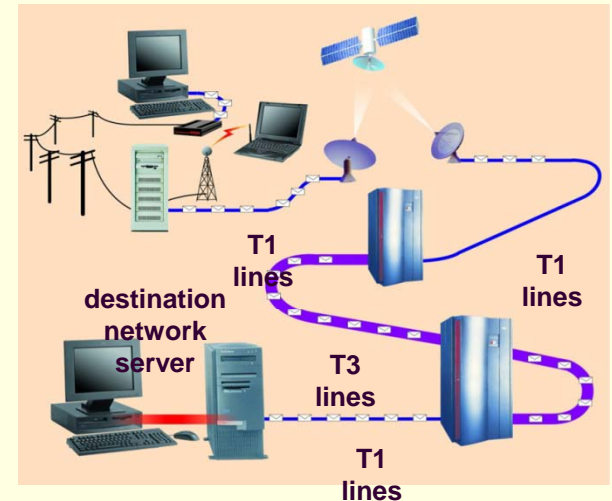

Physical Transmission Media

- A tangible media
 - Examples: Twisted-pair cable, coaxial cable, Fiber-optics, etc.
- **Twisted-pair cable:**
 - One or more twisted wires bundled together (why?)
 - Made of copper
- **Coax-Cable:**
 - Consists of single copper wire surrounded by three layers of insulating and metal materials
 - Typically used for cable TV
- **Fiber-optics:**
 - Strands of glass or plastic used to transmit light
 - Very high capacity, low noise, small size, less suitable to natural disturbances

Physical Transmission Media

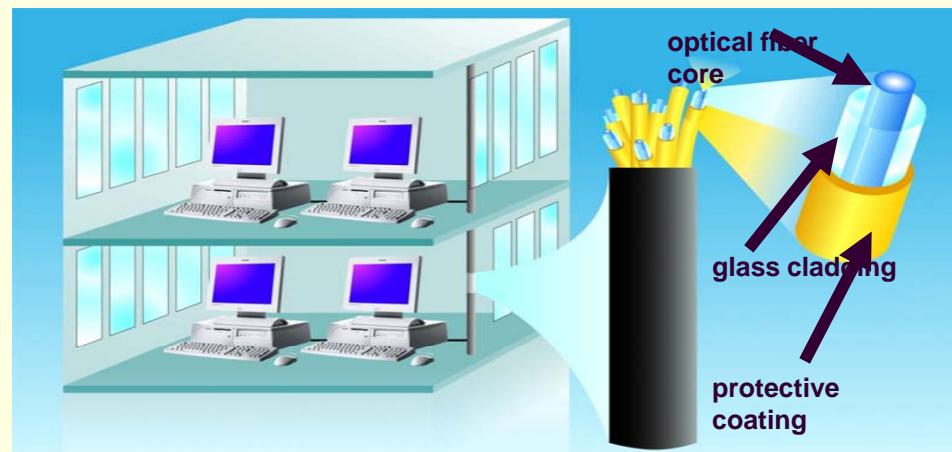
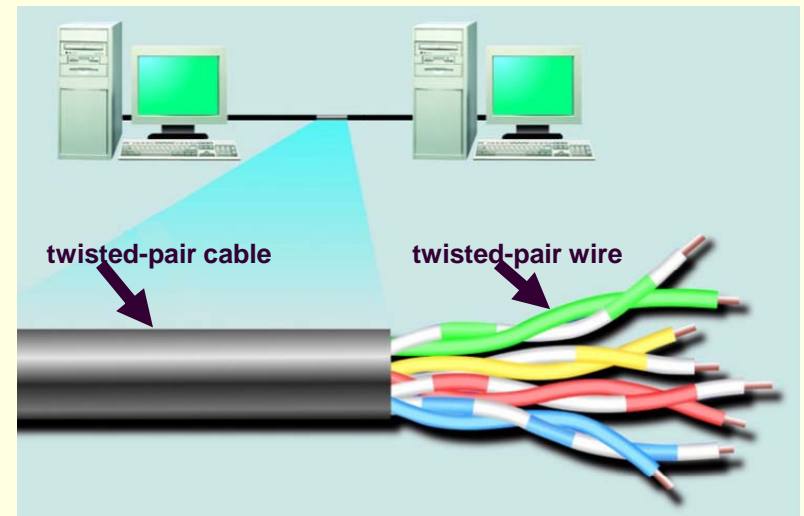
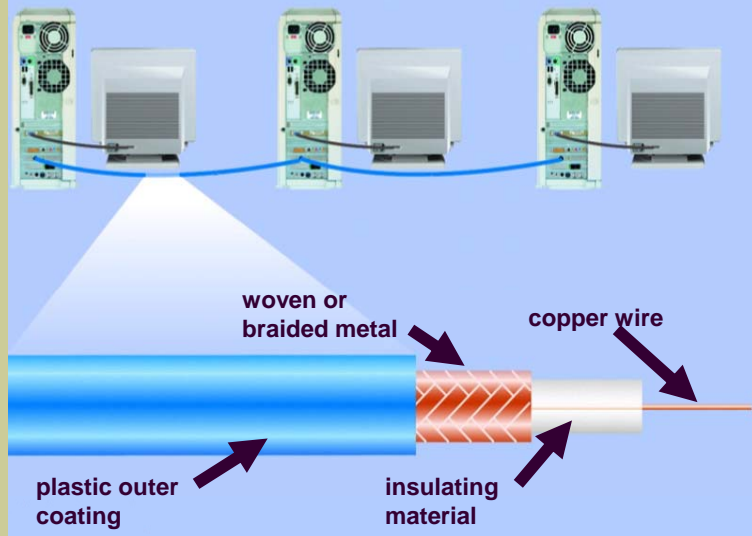

Wireless Transmission Media

- Broadcast Radio
 - Distribute signals through the air over long distance
 - Uses an antenna
 - Typically for stationary locations
 - Can be short range
- Cellular Radio
 - A form of broadcast radio used for mobile communication
 - High frequency radio waves to transmit voice or data
 - Utilizes frequency-reuse

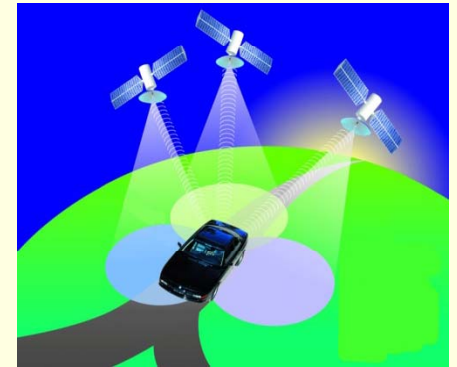

Wireless Transmission Media

- **Microwaves**

- Radio waves providing high speed transmission
- They are point-to-point (can't be obstructed)
- Used for satellite communication

- **Infrared (IR)**

- Wireless transmission media that sends signals using infrared light- waves - **Such as?**

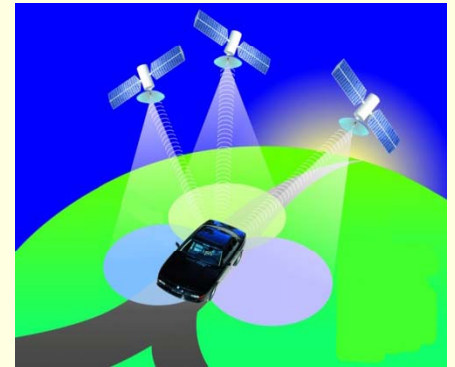

Physical Transmission Media

Type of Cable and LAN	Transfer Rates
Twisted Pair	
• 10Base-T (Ethernet)	10 Mbps
• 100Base-T (Fast Ethernet)	100 Mbps
• 1000Base-T (Gigabit Ethernet)	1000 Mbps
• Token ring	4 - 16 Mbps
Coaxial Cable	
• 10Base2 (ThinWire Ethernet)	10 Mbps
• 10Base5 (ThickWire Ethernet)	10 Mbps
Fiber-Optic Cable	
• 10Base-F (Ethernet)	10 Mbps
• 100Base-FX (Fast Ethernet)	100 Mbps
• FDDI (Fiber Distributed-Data Interface) token ring	100 Mbps

100 Mbps is how many bits per sec?

**Which is bigger:
10,000 Mbps, 0.01Tbps or 10Gbps?**

Wireless channel capacity:

Channel	Transfer Rates
Broadcast radio	Up to 2 Mbps
Microwave radio	45 Mbps
Communications satellite	50 Mbps
Cellular radio	9,600 bps to 14.4 Kbps
Infrared	1 to 4 Mbps

Networks

- Collection of computers and devices connected together
- Used to transfer information or files, share resources, etc.
- What is the largest network?
- Characterized based on their geographical coverage, speed, capacities
- Networks are categorized based on the following characteristics:
 - Network **coverage**: LAN, MAN, WAN
 - Network **topologies**: how the computers are connected together
 - Network **technologies**
 - Network **architecture**

Network coverage

- Local Area Networks:
 - Used for small networks (school, home, office)
 - Examples and configurations:
 - Wireless LAN or Switched LAN
 - ATM LAN, Frame Ethernet LAN
 - Peer-2-PEER: connecting several computers together (<10)
 - Client/Server: The server shares its resources between different clients
- Metropolitan Area Network
 - Backbone network connecting all LANs
 - Can cover a city or the entire country
- Wide Area Network
 - Typically between cities and countries
 - Technology:
 - Circuit Switch, Packet Switch, Frame Relay, ATM
 - Examples:
 - Internet P2P: Networks with the same network software can be connected together (Napster)

LAN v.s WAN

LAN - Local Area Network a group of computers connected within a building or a campus (Example of LAN may consist of computers located on a single floor or a building or it might link all the computers in a small company).

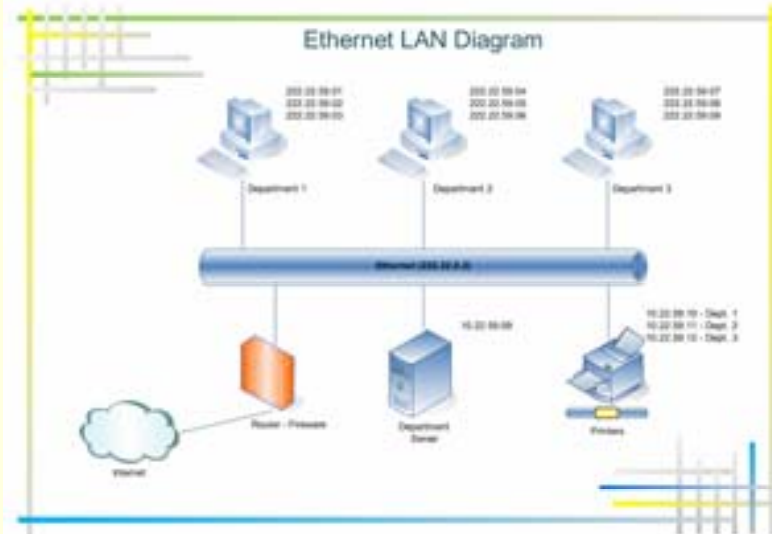
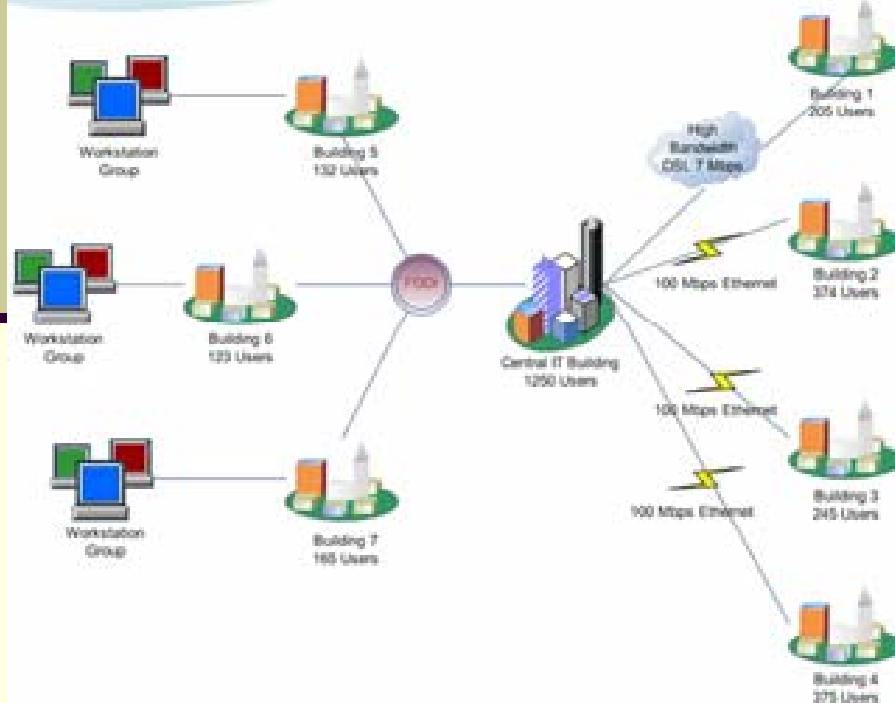

WAN - A network consisting of computers of LAN's connected across a distance WAN can cover small to large distances, using different topologies such as telephone lines, fiber optic cabling, satellite transmissions and microwave transmissions.

Network Topologies

- Configuration or physical arrangement in which devices are connected together
- BUS networks: Single central cable connected a number of devices
 - Easy and cheap
 - Popular for LANs
- RING networks: a number of computers are connected on a closed loop
 - Covers large distances
 - Primarily used for LANs and WANs
- STAR networks: connecting all devices to a central unit
 - All computers are connected to a central device called *hub*
 - All data must pass through the hub
 - What is the problem with this?
 - Susceptible to failure

Network Topologies

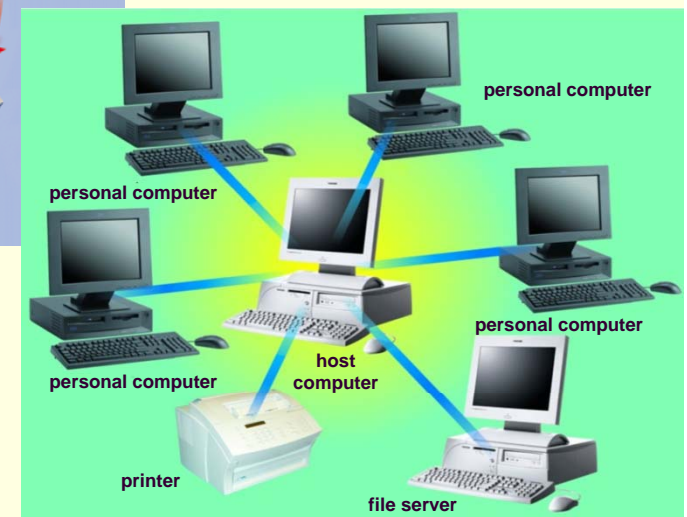
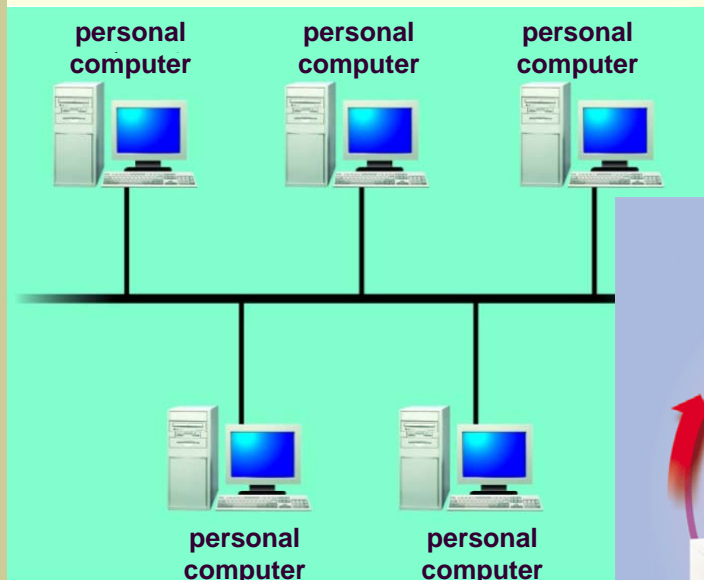

Network Architecture

- Refers to how the computer or devices are designed in a network
- Basic types:
 - Centralized – using mainframes
 - Peer-2-Peer:
 - Each computer (peer) has equal responsibilities, capacities, sharing hardware, data, with the other computers on the peer-to-peer network
 - Good for small businesses and home networks
 - Simple and inexpensive
 - Client/Server:
 - All clients must **request** service from the server
 - The server is also called a **host**
 - Different servers perform different tasks: *File server, network server, etc.*



P2P vs Client-Server

Peers make a portion of their resources, such as processing power, disk storage or network bandwidth, directly available to other network participants, without the need for central coordination by servers or stable hosts

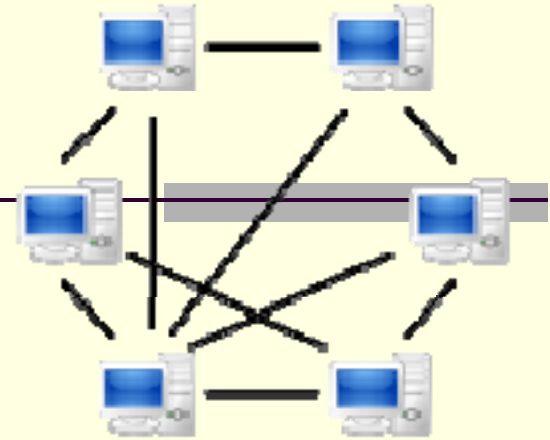

Peer-to-Peer Examples

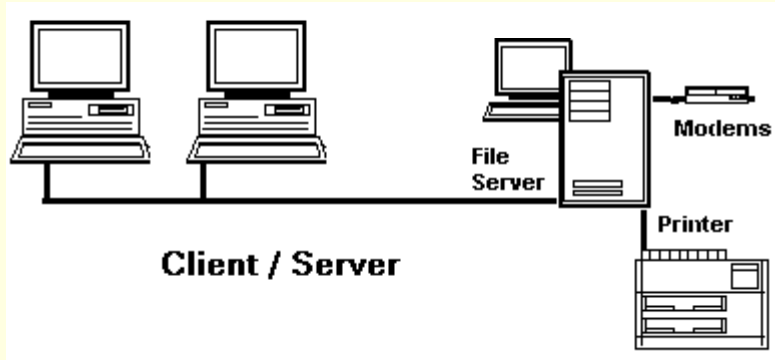
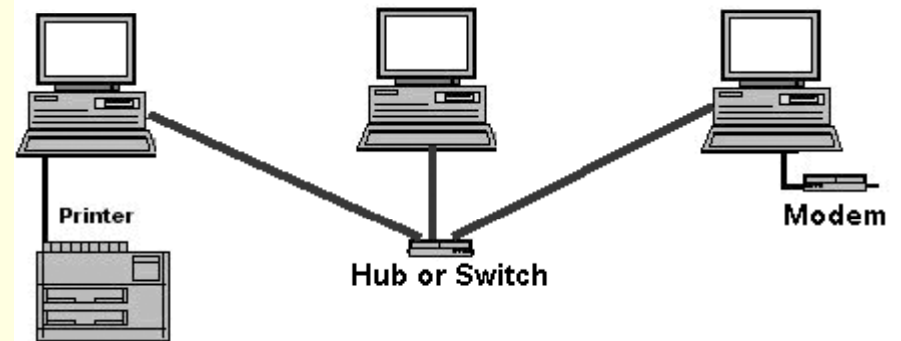

Client / Server

(Data) Network Technologies

- Vary depending on the type of devices we use for interconnecting computers and devices together
- Ethernet:
 - LAN technology allowing computers to access the network
 - Susceptible to collision
 - Can be based on BUS or STAR topologies
 - Operates at 10Mbps or 100Mbps, (10/100)
 - Fast Ethernet operates at 100 Mbps /
 - Gigabit Ethernet (1998 IEEE 802.3z)
 - 10-Gigabit Ethernet (10GE or 10GbE or 10 GigE)
 - 10GBASE-R/LR/SR (long range short range, etc.)
- Physical layer
 - Gigabit Ethernet using optical fiber, twisted pair cable, or balanced copper cable

(Data) Network Technologies

- Token Ring
 - LAN technology
 - Only the computer with the token can transmit
 - No collision
 - Typically 72-260 devices can be connected together
- TCP/IP and UDP
 - Uses packet transmission
- 802.11
 - Standard for wireless LAN
 - Wi-Fi (wireless fidelity) is used to describe that the device is in 802.11 family or standards
 - Typically used for long range (300-1000 feet)
 - Variations include: **.11** (1-2 Mbps); **.11a** (up to 54 Mbps); **.11b** (up to 11 Mbps); **.11g** (54 Mbps and higher)

(Data) Network Technologies

- 802.11n
 - Next generation wireless LAN technology
 - Improving network throughput (600 Mbps compared to 450 Mbps) – thus potentially supporting a user throughput of 110 Mbit/s
- WiMAX
 - *Worldwide Interoperability for Microwave Access*
 - Provides wireless transmission of data from point-to-multipoint links to portable and fully mobile internet access (up to 3 Mbit/s)
 - The intent is to deliver the last mile wireless broadband access as an alternative to cable and DSL
 - Based on the IEEE 802.16(d/e) standard (also called Broadband Wireless Access)

Network Technologies



- **Personal area network (PAN)**
 - A low range computer network
 - PANs can be used for communication among the personal devices themselves
 - Wired with computer buses such as USB and FireWire.
- **Wireless personal area network (WPAN)**
 - Uses network technologies such as IrDA, Bluetooth, UWB, Z-Wave and ZigBee
- **Internet Mobile Protocols**
 - Supporting multimedia Internet traffic
 - IGMP & MBONE for multicasting
 - RTP, RTCP, & RSVP (used to handle multimedia on the Internet)
- **VoIP**

Network Technologies

- Zigbee
 - High level communication protocols using small, low-power digital radios based on the IEEE 802.15.4
 - Wireless mesh networking proprietary standard
- Bluetooth
 - Uses radio frequency
 - Typically used for close distances (short range- 33 feet or so)
 - Transmits at 1Mbps
 - Used for handheld computers to communicate with the desktop
- IrDA
 - Infrared (IR) light waves
 - Transfers at a rate of 115 Kbps to 4 Mbps
 - Requires light-of-sight transmission
- RFID
 - Radio frequency identification
 - Uses tags which are places in items
 - Example: merchandises, toll-tags, courtesy calls, sensors!
- WAP
 - Wireless application protocol
 - Data rate of 9.6-153 kbps depending on the service type
 - Used for smart phones and PDAs to access the Internet (email, web, etc)

Network Examples

- IEEE 802.15.4
 - Low-rate wireless personal area networks (LR-WPANs)
 - Bases for e ZigBee, WirelessHART, and MiWi specification
 - Also used for 6LoWPAN and standard Internet protocols to build a Wireless Embedded Internet (WEI)
- Intranets
 - Used for private networks
 - May implement a firewall
 - Hardware and software that restricts access to data and information on a network
- Home networks
 - Ethernet
 - Phone line
 - HomeRF (radio frequency- waves)
 - Intelligent home network
- Vehicle-to-Vehicle (car2Car) - <http://www.car-to-car.org/>
 - A wireless LAN based communication system to guarantee European-wide inter-vehicle operability

Network Examples

■ Interplanetary (Internet) Network

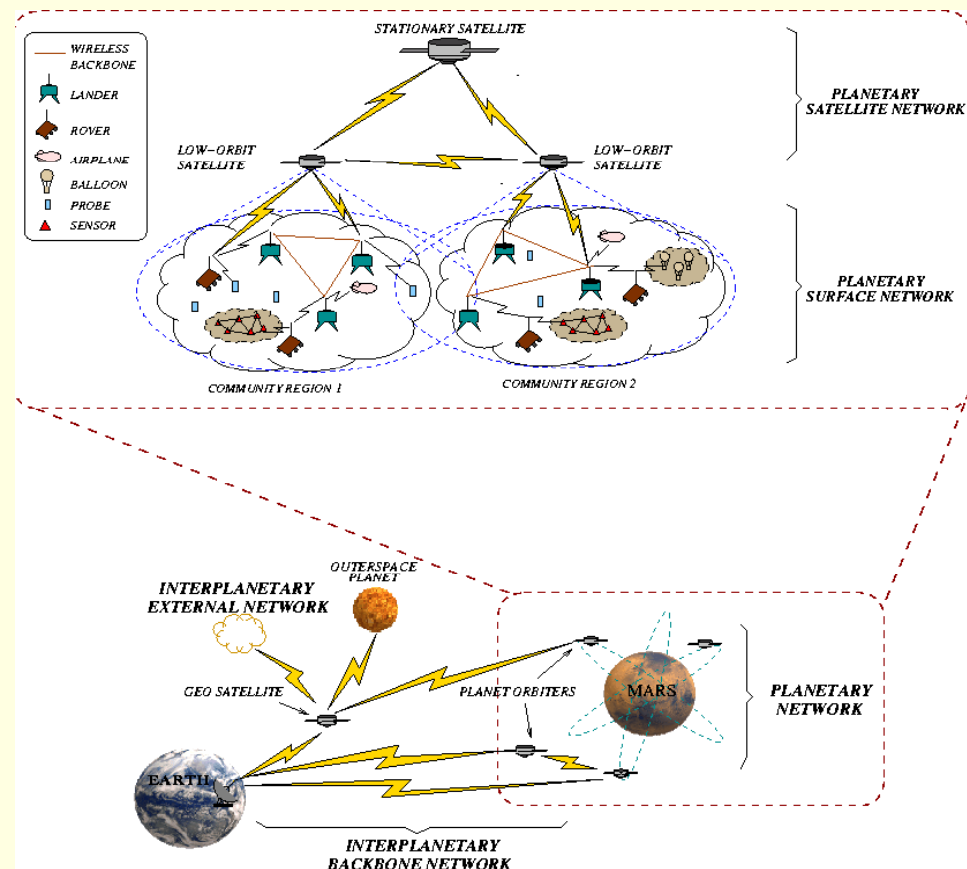

Network Example:

Telephone Networks

- Called the Public Switched Telephone Network (PSTN)
- World-wide and voice oriented (handles voice and data)
- Data/voice can be transferred within the PSTN using different technologies (data transfer rate bps)
- Dial-up lines:
 - Analog signals passing through telephone lines
 - Requires modems (56 kbps transfer rate)
- ISDN lines:
 - Integrated Services Digital Network
 - Digital transmission over the telephone lines
 - Can carry (multiplex) several signals on a single line
- DSL
 - Digital subscribe line
 - ADSL (asymmetric DSL)
 - receiver operated at 8.4 Mbps, transmit at 640 kbps
- T-Carrier lines: carries several signals over a single line: T1,T3
- Frame Relay
- ATM:
 - Asynchronous Transfer Mode
 - Fast and high capacity transmitting technology
 - Packet technology

Switching Technologies:
Technologies:

- Circuit Switching
- Packet Switching
- Message Switching
- Burst Switching

Network Example:

Optical Networks

- Fiber-to-the-x
 - Broadband network architecture that uses optical fiber to replace copper
 - Used for last mile telecommunications
 - Examples: Fiber-to-the-home (FTTH); Fiber-to-the-building (FTTB); Fiber-to-the premises (FTTP)
- Fiber Distribution Network (reaching different customers)
 - Active optical networks (AONs)
 - Passive optical networks (PONs)

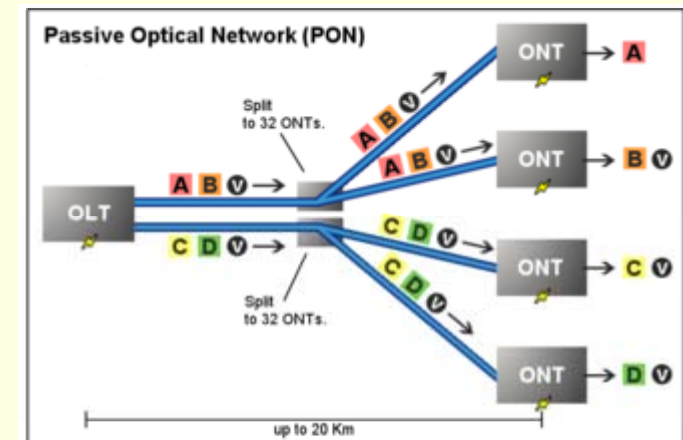
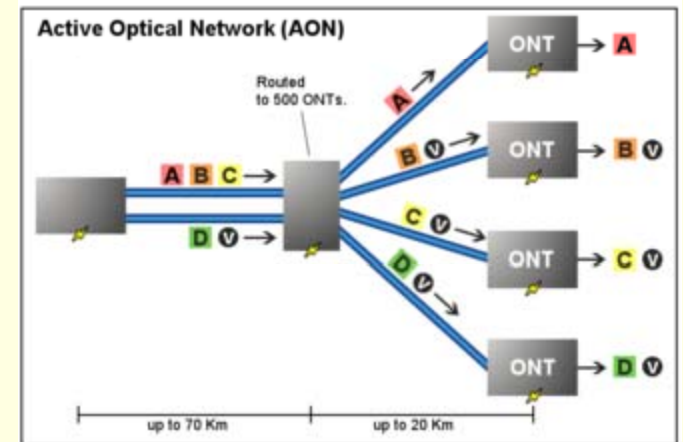

Network Example

- Smart Grid
 - Delivering electricity from suppliers to consumers using digital technology to save energy
- Storage Area Networks
- Computational Grid Networks

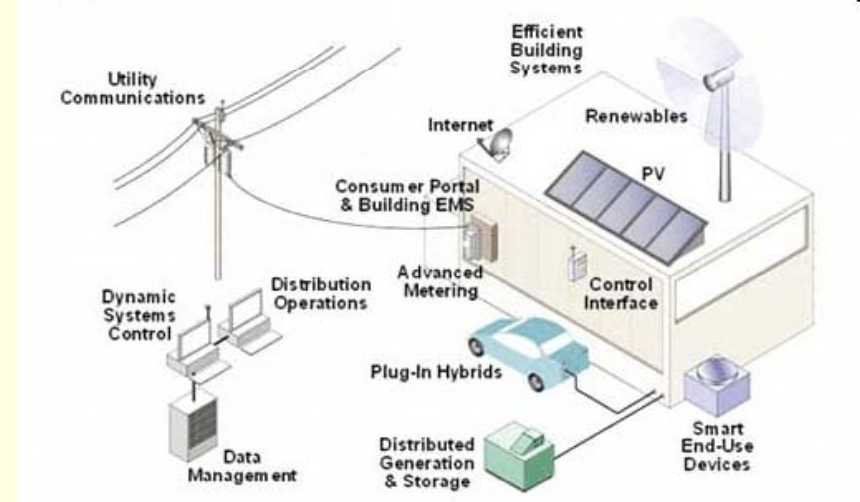

Network Example:

Telephone Networks

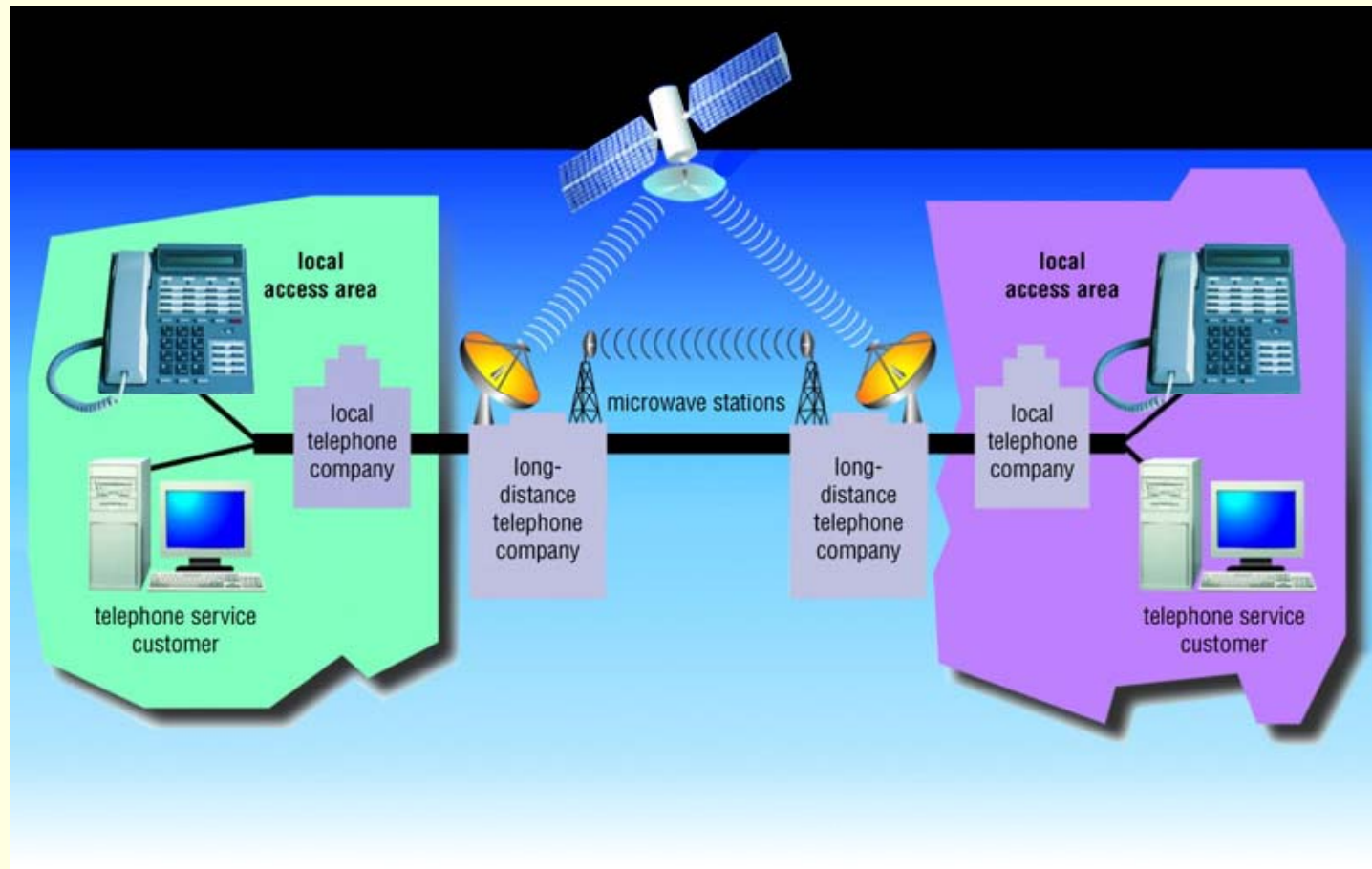

Network Examples

Type of Line	Transfer Rates	Approximate Monthly Cost
Dial-up	Up to 56 Kbps	Local or long-distance rates
ISDN (BRI)	Up to 128 Kbps	\$10 to \$40
ADSL	128 Kbps – 9 Mbps	\$40 to \$80
Cable TV (CATV)	128 Kbps – 2.5 Mbps	\$30 to \$50
T1	1.544 Mbps	\$1,000 or more
T3	44 Mbps	\$10,000 or more
ATM	155 Mbps to 622 Mbps	\$8,000 or more

Network Examples

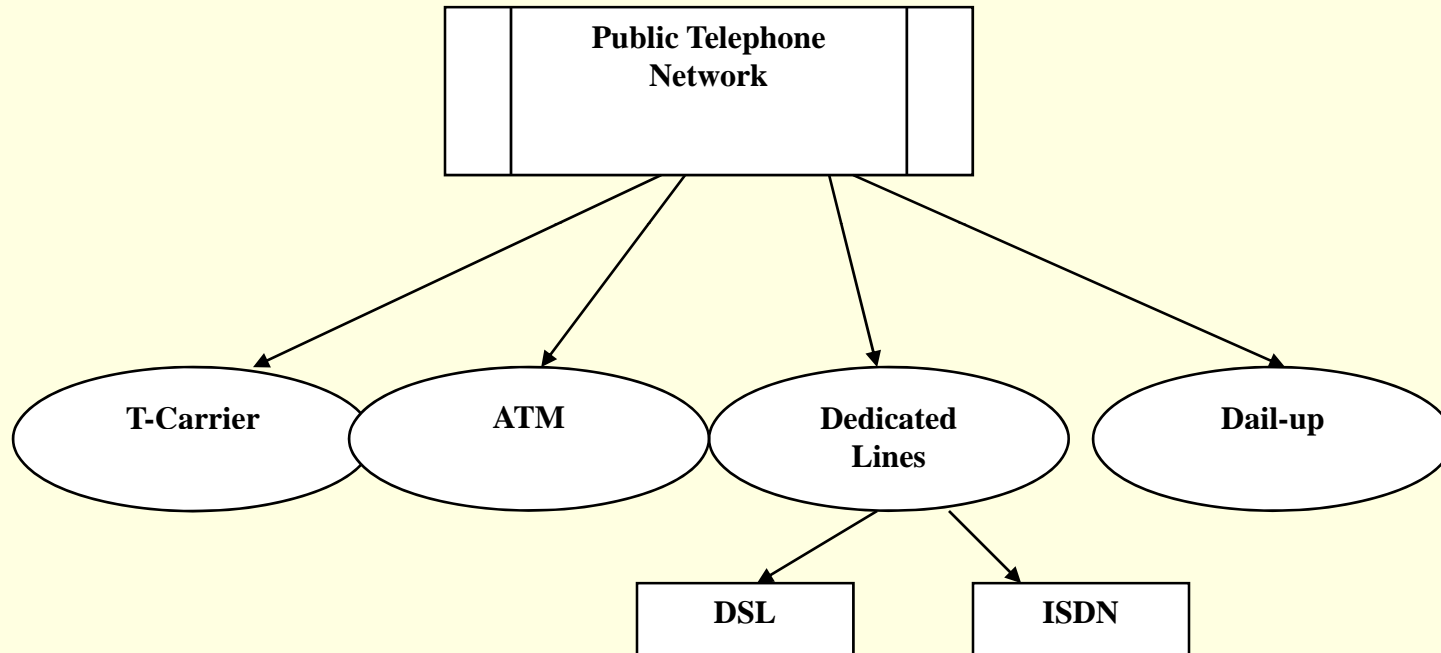

What about Cable Internet Services?

Cellular Network Examples

■ 0G

- Single, powerful base station covering a wide area, and each telephone would effectively monopolize a channel over that whole area while in use (developed in 40's)
- No frequency use or handoff (basis of modern cell phone technology)

■ 1G

- Fully automatic **cellular networks**
- introduced in the early to mid 1980s

■ 2G

- Introduced in 1991 in Finland on the GSM standard
- Offered the first data service with person-to-person SMS text messaging

Cellular Network Examples

- 3G:

- Faster than PCS; Used for multimedia and graphics
- Compared to 2G and 2.5G services, 3G allows simultaneous use of speech and data services and higher data rates (up to 14.4 Mbit/s on the downlink and 5.8 Mbit/s.

- 4G:

- Fourth generation of cellular wireless;
- providing a comprehensive and secure IP based service to users "Anytime, Anywhere" at high data rates

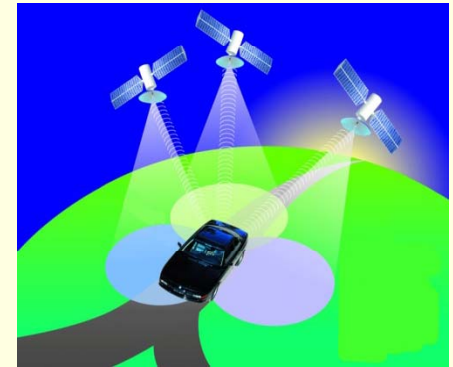

Merging Technologies

- m-Cash
 - Pay using your cell phone
- Scan-free shopping using Radio frequency identification
- VeriChip
 - Implanted computer chip in the body!
- RFID
- Wearable computer technology
 - Implanting a cell phone in your tooth!
- Power over Ethernet (PoE)
 - Transferring electrical power, along with data, to remote devices over standard category 5 cable in an Ethernet network
 - PoE Plus (802.3at) provides more available power
 - Power over fiber?

Merging Technologies

- Ethernet over powerline
 - allowing to route data packets through the electrical lines
 - Up to 200 times faster than DSL (200 Mbps)
 - Useful when concrete, metal, or other obstructions in the walls and wireless cannot operate well
- Energy-efficient Ethernet
 - IEEE P802.3az Energy Efficient Ethernet Task Force
 - mechanism to reduce power consumption during periods of low link utilization
 - No frames in transit shall be dropped or corrupted during the transition to and from the lower level of power consumption
 - Uses low-power idle proposal for use with 100 Mbit and Gbit connections (causing possible latency for 10G-bit Ethernet)

